



**Anglo-Chinese School
(Primary).**

A Methodist Institution
(Founded 1886)

**SEMESTRAL ASSESSMENT ONE 2021
SCIENCE
PRIMARY SIX
BOOKLET A**

Name: _____ () Class: Primary 6 _____

Date: 17 May 2021

Total Time for Booklets A and B: 1 h 45 min

Additional Materials: Optical Answer Sheet (OAS)

INSTRUCTIONS TO CANDIDATES

1. Write your name, index number and class in the spaces provided.
2. Do not turn over this page until you are told to do so.
3. Follow all instructions carefully.
4. Answer all questions.
5. Shade your answer on the Optical Answer Sheet (OAS) provided.

For each question from 1 to 28, four options are given. One of them is the correct answer.
Make your choice (1, 2, 3 or 4) and shade your answer on the Optical Answer Sheet.

(56 marks)

- 1 The picture shows an animal, X.

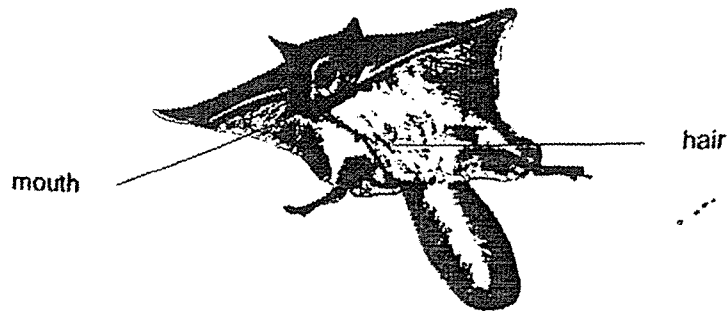

Some students made the following statements about animal X.

- A X is a mammal as it has hair.
- B X is a bird because it has wings.
- C X is not a bird as it does not have a beak.

Which of the statement(s) is/are correct?

- (1) C only
 - (2) A and B only
 - (3) A and C only
 - (4) A, B and C
- 2 Which of the following happens during pollination?

- (1) The ovules become seeds.
- (2) The petals drop off the flower.
- (3) The stigma receives pollen grains.
- (4) The pollen grain fertilises the female reproductive cell.

- 3 The diagrams show two animals.



How are the animals similar?

- (1) have lungs
 - (2) have scales
 - (3) hatch from eggs
 - (4) have a four-stage life cycle
- 4 Five people were trapped in a lift for thirty minutes. Fresh air was unable to enter the lift.



Which of the following shows the most likely changes in the amount of different gases in the lift after thirty minutes?

	Oxygen	Carbon dioxide	Water vapour
(1)	increase	decrease	increase
(2)	increase	decrease	no change
(3)	decrease	increase	increase
(4)	decrease	increase	no change

- 5 A,B,C,D,E and F are organs in the digestive system. The graph show the amount of undigested food in each organ of the digestive system.

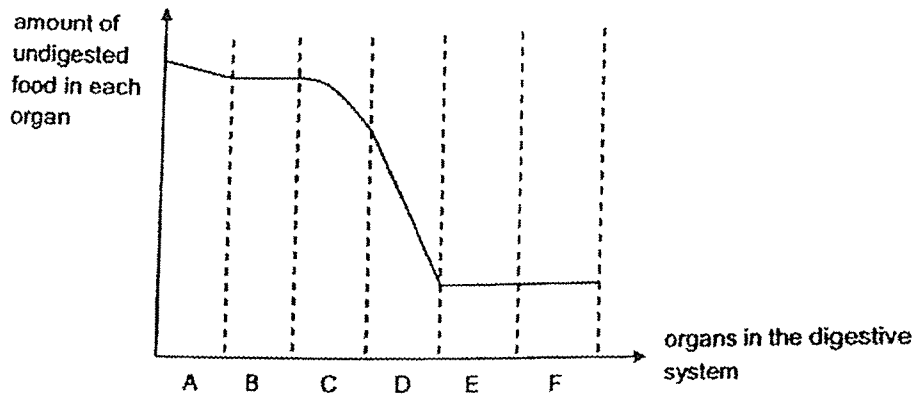

In the diagram of the human digestive system below, which part of the digestive system, W, X, Y or Z, matches organ D of the graph?

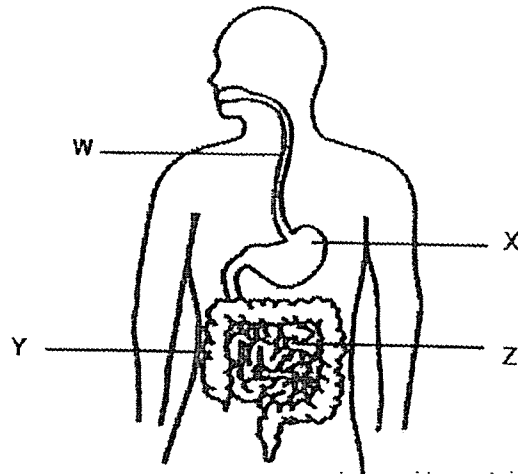

- (1) W
- (2) X
- (3) Y
- (4) Z

6. The flowchart shows three types of cells, A, B, C,

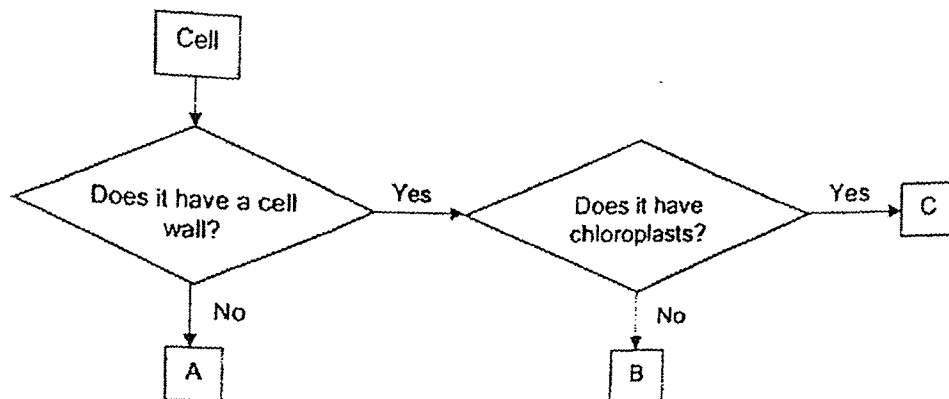

Which of the following most likely represents cells A, B and C?

	A	B	C
(1)	leaf cell	cheek cell	root cell
(2)	root cell	cheek cell	leaf cell
(3)	cheek cell	leaf cell	root cell
(4)	cheek cell	root cell	leaf cell

7. Ben counted the number of plants in the Science garden and recorded his findings in the following table.

Type of Plant	Number of plant
Rose	5
Daisy	3
Orchid	2
Sunflower	10

Which of the following statements is correct?

- (1) There are seven populations of plants.
- (2) There are twenty communities of plants.
- (3) The smallest population of plants is Orchid.
- (4) The largest community of plants is Sunflower.

8. The graph shows the effect of temperature on the populations of three different bacteria Q, R and S.

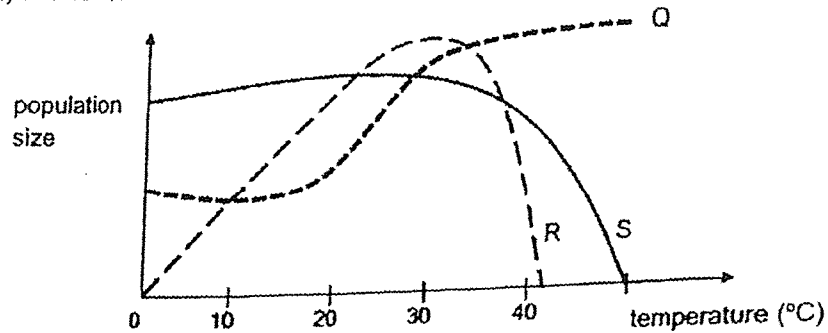

Which of the following statements is incorrect?

- (1) The population of S decreases after 15°C.
 - (2) The population of R reaches zero after 40°C.
 - (3) The population of R is the highest around 30°C.
 - (4) The population of Q and R are the same at 10°C.
- 9 The diagram shows a food chain in a habitat.



A new population, W, is introduced into the habitat. W feeds on X only and it has no predators. Which of the following statements are correct?

- A The population of X would decrease.
 - B The population of Y would increase.
 - C The population of Z would decrease.
 - D The population of Z would remain the same.
- (1) A and C only
 - (2) A and D only
 - (3) B and C only
 - (4) C and D only

10. John wants to find out how mealworms respond to different temperatures. Four containers with some mealworms and bread slices were placed in different locations as shown,

Container	Number of mealworms	Number of bread slices	Location
P	10	1	garden
Q	20	1	garden
R	20	1	air-conditioned room
S	10	2	air-conditioned room

Which two containers should John use to make experiment a fair test?

- (1) P and Q
 - (2) P and R
 - (3) Q and R
 - (4) R and S
- 11 Study the food web below.

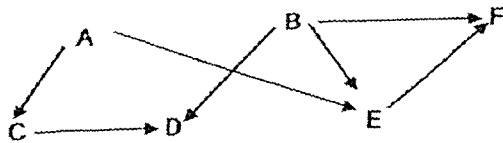

Which of the statements is incorrect?

- (1) E is eaten by F only.
- (2) A and B are producers.
- (3) C and E are plant-eaters.
- (4) D and E are plant-and-animal eaters.

12. Four different types of organisms, P, Q, R, and S live in a habitat. The graph shows the effects on the three organisms Q, R, and S when majority of organism P died of a disease,

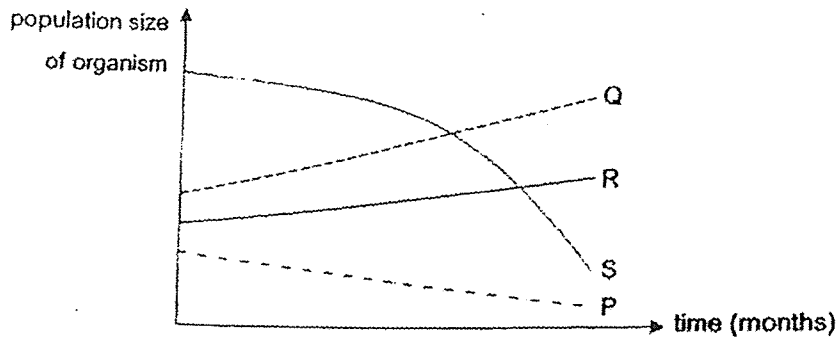

Which organism(s) does P most likely feed on?

- (1) S only
- (2) Q and R
- (3) Q and S
- (4) R and S

13. Ross set up the following apparatus to find out how much light can pass through objects W, X, Y and Z. He placed each object in front of the torchlight and measured the amount of light that passed through each object.

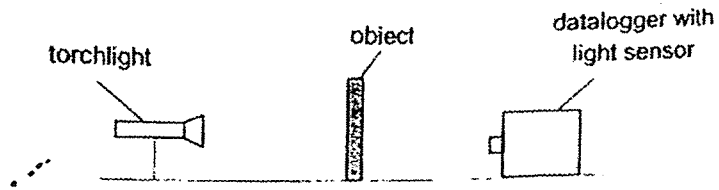

His results from the datalogger are as shown.

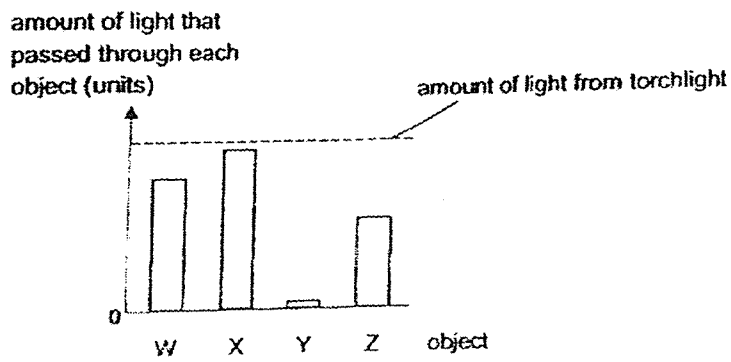

Which of the following is correct based on the results?

- (1) Y is most likely a wooden board.
- (2) X allows the most light to pass through.
- (3) Z allows more light to pass through than W.
- (4) Light did not pass through some of the materials.

- 14 The diagram shows a device used to clean window panes. When part A is moved across the inner surface of the window pane, part B moves together with it across the outer surface of the window pane.

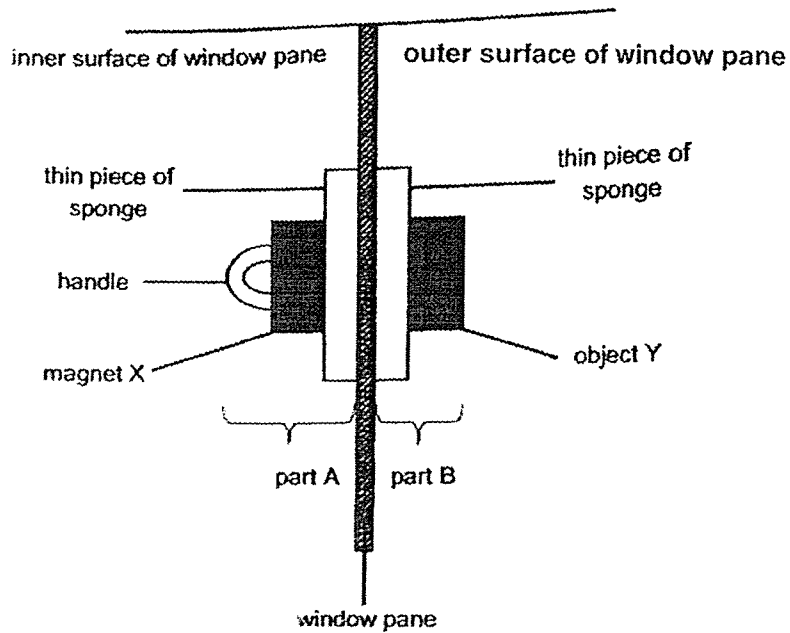

Which of the following statement(s) about the device is/are correct?

- A Object Y could be made of copper.
- B Magnet X attracted the sponges, which attracted object Y.
- C There is a force of attraction between magnet X and object Y.
- (1) B only
- (2) C only
- (3) A and B only
- (4) A and C only

- 15 The diagram shows five batteries, one bulb and four switches, S1, S2, S3, and S4. All batteries and switches are identical.

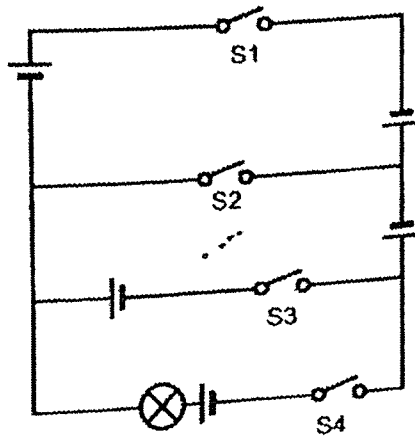

Which switches should be closed in order for the bulb to shine most brightly?

- (1) S1 and S4 only
- (2) S2 and S4 only
- (3) S3 and S4 only
- (4) S1, S2 and S3 only

16. A beaker of water at around 30 C was heated for 20 minutes until it boiled. the temperature change was measured and recorded in a graph. Which of the following correctly shows the change in temperature?

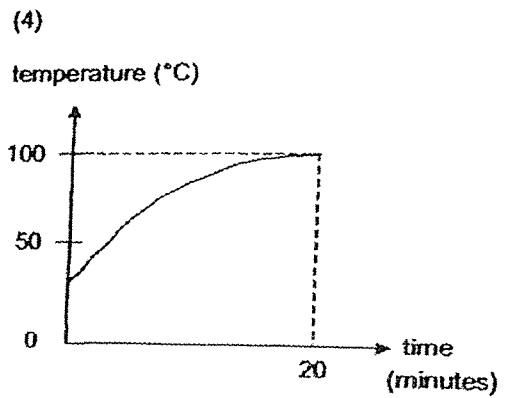
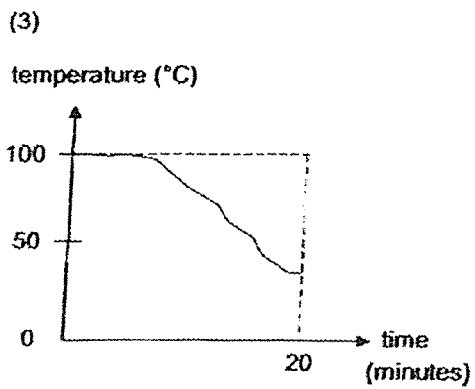
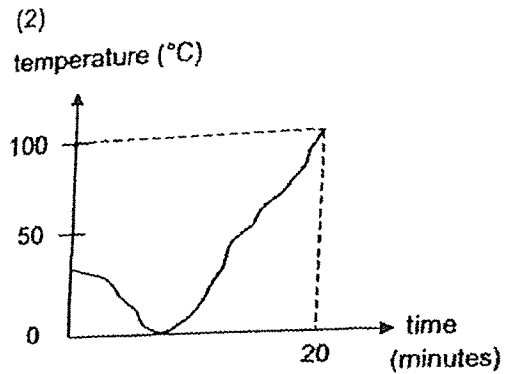
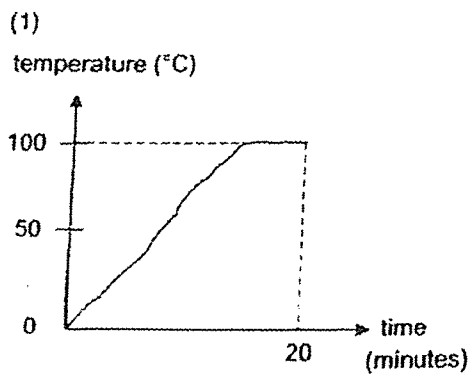

- 17 Which of the following source of energy is renewable?

- (1) coal
- (2) wind
- (3) petroleum
- (4) natural gas

- 18 Containers R and S are the same size but made of different materials. A lamp was placed equal distance to the containers. It was observed that the ice cube in container R melted first.

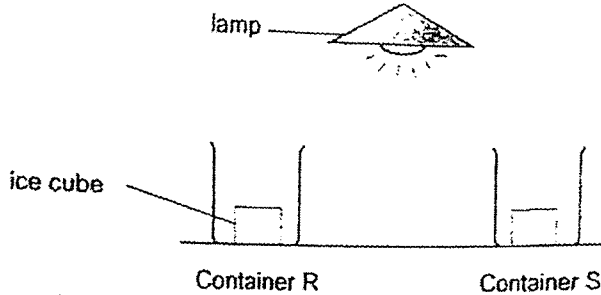

Which of the following is most likely true?

- (1) There was more light energy that reached container S.
 - (2) More light energy was converted to heat energy at container S.
 - (3) More heat energy was transferred to the ice cube from container R.
 - (4) The melting point of the ice cube in container S was higher than in container R.
- 19 Pete boiled a pot of water and observed that the lid moved up and down as the water was boiling.

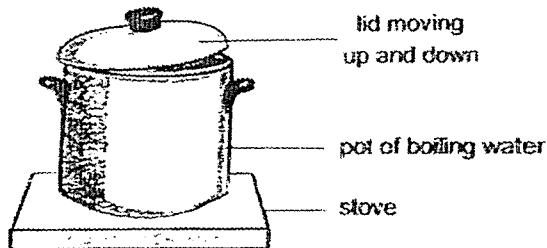

Which of the following describes the correct energy conversion that caused the lid to move up and down?

- (1) Heat energy in the steam is converted to kinetic energy of the lid.
- (2) Kinetic energy of the steam is converted to kinetic energy of the lid.
- (3) Heat energy from the stove is converted to kinetic energy of the steam.
- (4) Kinetic energy of the boiling water is converted to heat energy of the steam.

20. Solar panels are placed on the rooftops of some house to produce electricity.

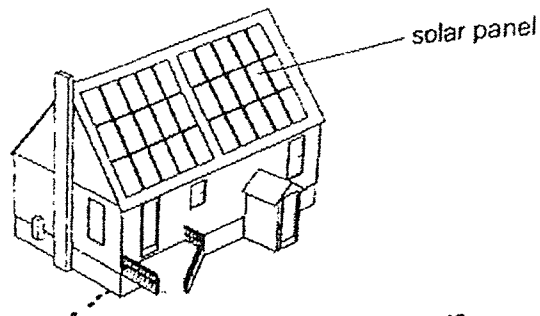

Which conversion of energy takes place at the solar panel?

- (1) light energy \rightarrow electrical energy
 - (2) electrical energy \rightarrow light energy
 - (3) heat energy \rightarrow electrical energy
 - (4) potential energy \rightarrow electrical energy
- 21 A rubber band is stretched and released at point A. It takes the path as shown below where it stops at point C.

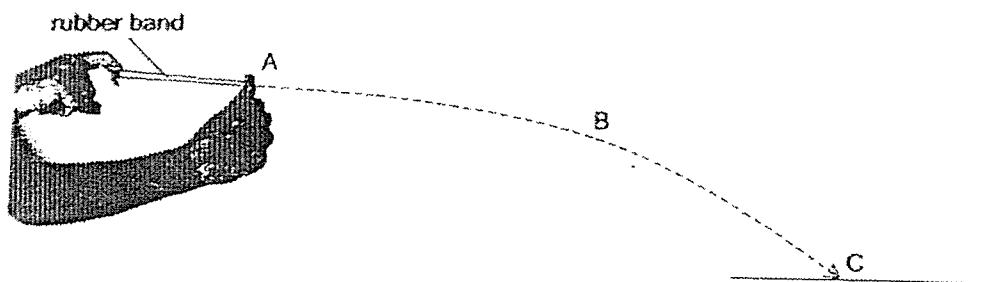

Which of the following is most likely true?

- (1) At point A, the rubber band has the most potential energy.
- (2) At point B, the rubber band has kinetic energy only.
- (3) At point C, the rubber band has kinetic energy.
- (4) Conversion of energy happens only at point A.

22. Two similar wooden blocks, A, and B, slid down two similar slopes after they were released from the same height. Block A was coated with a thin layer of oil but block B was not. Points P and Q are exactly halfway down the slopes.

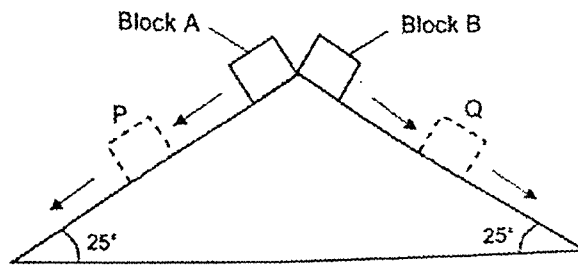

Which graph correctly shows the amount of potential energy at point P and Q?

(1)

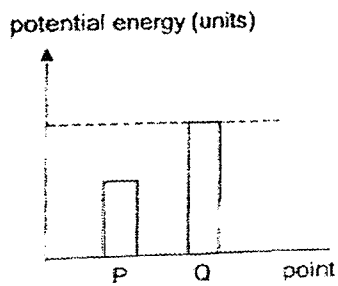

(2)

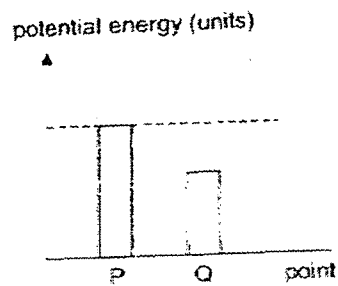

(3)

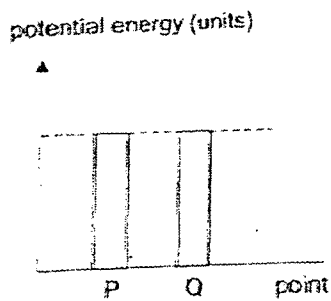

(4)

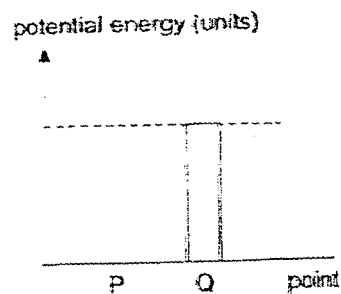

23. ball A is released from a height and hits ball B. Ball B moves up a slope to point X and then moves back in the opposite direction.

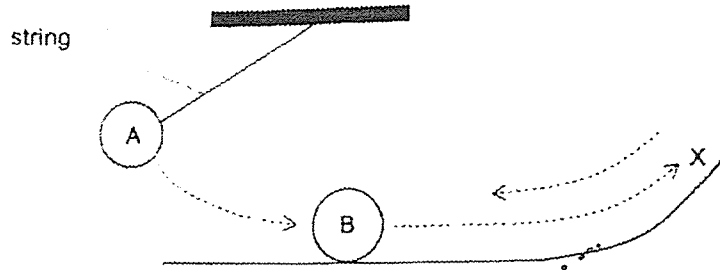

Which of the following is most likely true about balls A and B during this process?

- (1) Ball B still has some kinetic energy as it moves back.
 - (2) Gravitational potential energy of ball A increases only.
 - (3) Ball A has gravitational potential energy only as it moves towards B.
 - (4) Kinetic energy of ball A is converted to heat and sound energy only.
- 24 Which of the following does not have potential energy?
- (1) an unripe banana
 - (2) an apple on a table
 - (3) a shadow on a screen
 - (4) a ball bouncing off the floor

25. Tom conducted the following experiment by hanging a ball on a spring and measuring the length of the spring.

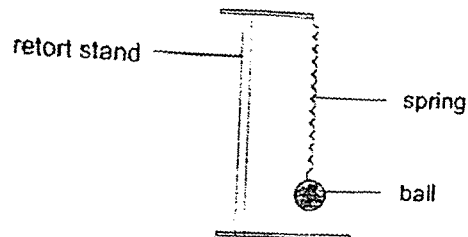

He repeated his experiment with balls of different masses and recorded his results below.

Ball	Mass (g)	Length of spring (cm)
W	20	12
X	25	14
Y	30	16
Z	35	18

Which of the conclusions is true based on the results of the experiment?

- (1) The lighter the ball, the longer the length of the spring.
- (2) The heavier the ball, the longer the length of the spring.
- (3) The mass of the ball does not affect the energy that the spring has.
- (4) The mass of the ball does not affect the upward distance travelled by the ball.

26. The diagrams A, B, C and D show actions that require different types of forces.

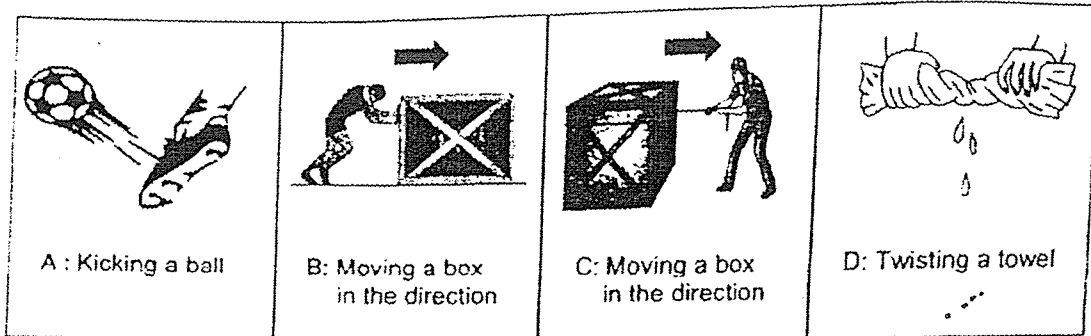

Which of the following correctly shows how the actions can be grouped?

	Push	Pull	Push and Pull
(1)	A and B	C	D
(2)	B and C	A	D
(3)	B	C	A and D
(4)	C and D	A	B

27. An athlete threw a javelin in a competition. The javelin travelled through the air following the path as shown.

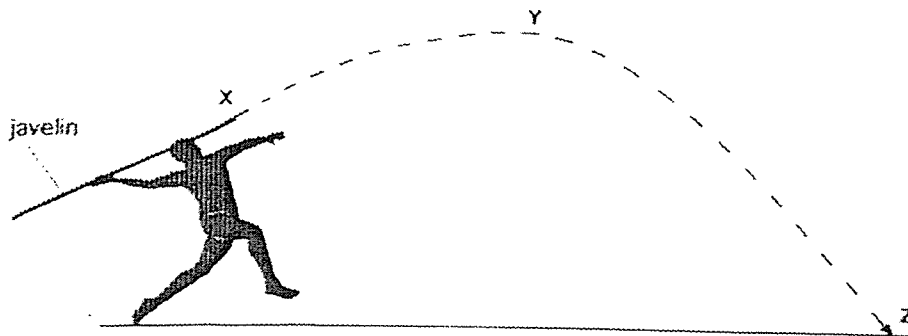

At which point(s) does gravitational force act on the javelin?

- (1) Y only
- (2) X and Y only
- (3) Y and Z only
- (4) X, Y and Z

- 28 Jim placed a magnet at the top of a ramp as shown in the diagram.

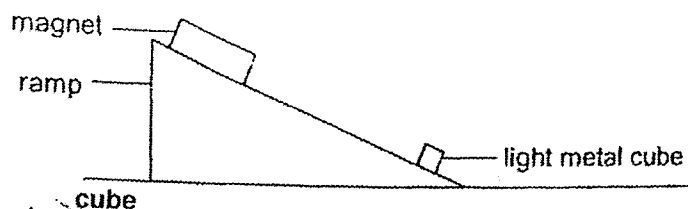

He placed a ball at the bottom of the ramp. When he moved the magnet down the ramp slowly, the light metal cube moved up the ramp and towards the magnet on its own. Which of the following force(s) was/were acting on the light metal cube as it moved up the ramp?

- A: frictional force
 - B: magnetic force
 - C: gravitational force
 - D: elastic spring force
- (1) B only
- (2) A and C only
- (3) A, B and C only
- (4) B, C and D only

(Go on to Booklet B)



Anglo-Chinese School
(Primary)

A Methodist Institution
(Founded 1886)

SEMESTRAL ASSESSMENT ONE 2021
SCIENCE
PRIMARY SIX
BOOKLET B

Name: _____ ()

Class: Primary 6 _____

Date: 17 May 2021

Total Time for Booklets A and B: 1 h 45 min

Parent's / Guardian's signature

INSTRUCTIONS TO CANDIDATES

1. Write your name, index number and class in the spaces provided.
2. Do not turn over this page until you are told to do so.
3. Follow all instructions carefully.
4. Answer all questions.
5. Write your answers in this booklet.

BOOKLET	MAX MARKS	MARKS OBTAINED
A	56	
B	44	
Total	100	

This question paper consists of 17 printed pages including this cover page.

For questions 29 to 40, write your answers in this booklet.

The number of marks available is shown in brackets [] at the end of each question or part question. (44 marks)

- 29 The graph shows the changes in Ajay's heart rate when he ran to catch the bus, while seated on the bus and during his walk home after he alighted from the bus. His resting heart rate was 65 beats per minute.

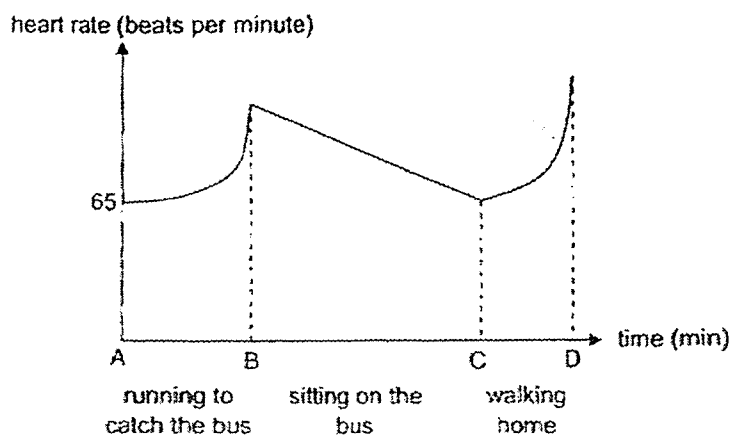

- (a) Why did Ajay's heart rate increase during the period AB? [1]

- (b) Explain which part of the graph, BC or CD, was drawn incorrectly. [1]

(Go on to the next page)

Score	2
-------	---

30 In fruit farms, farmers often remove a strip of bark on branches with fruits on them. This technique allows farmers to produce bigger fruits on those branches.

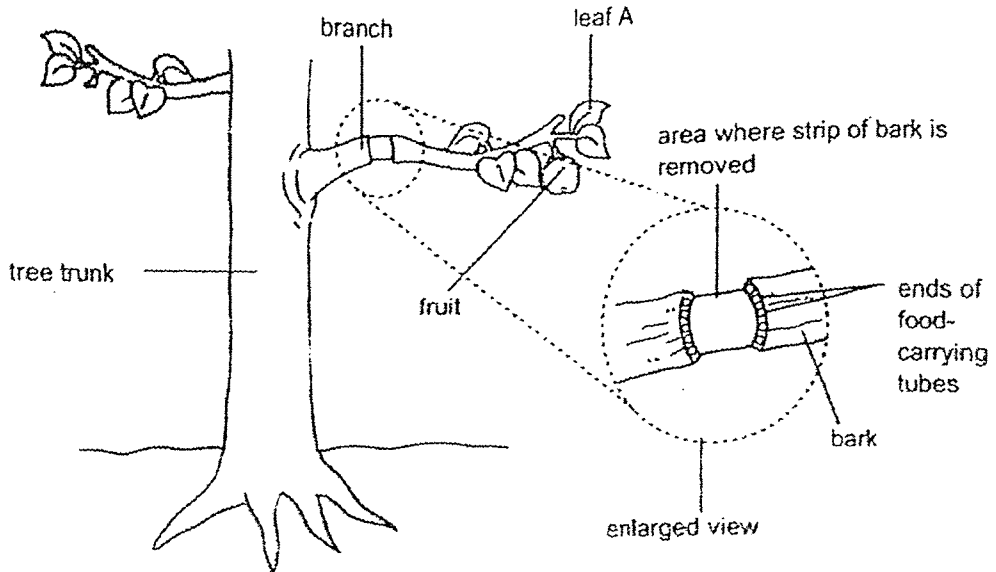

(a) Explain why removing the bark does not affect leaf A's ability to make food. [1]

(b) Explain how this technique helps to produce bigger fruits on these branches. [2]

(Go on to the next page)

Score	3
-------	---

31 The diagram in the space below shows a plant cell

- (a) Name and label the part that:
- contains genetic information; and
 - gives the cell a regular shape.

Use ruler and pencil to name and label.

[2]

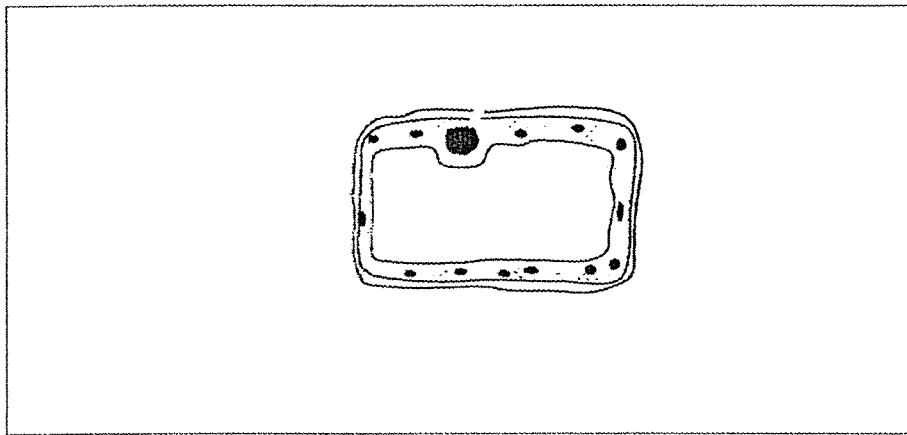

Kathy hung an empty bag from a rod into beaker of substance X as show at the start of the diagram. After some time, she observed that the bag had become bigger and its contents had changed.

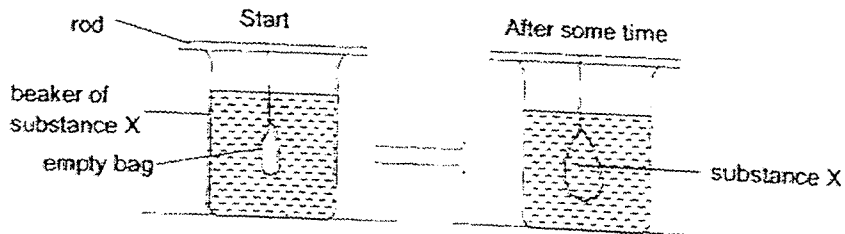

- (b) Which part of a cell represents the bag? Explain your answer. [2]

(Go on to the next page)

Score	/
	4

32. The interactions of organisms A to G living in a habitat is shown by the following food web.

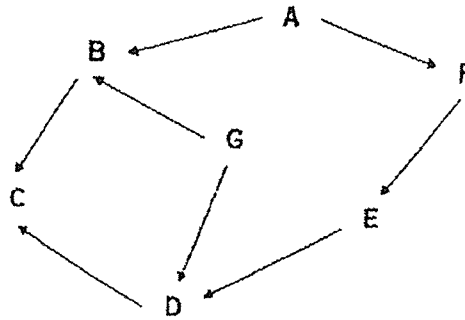

(a) Identify the following groups of organisms in the food web by filling in the blanks in the table below with the letters, A, B, C, D, E, F and G. [You need not use all the letters] [3]

Group of organisms	Organisms
food producer(s)	
plant-eater(s)	
plant-and-animal-eater(s)	

Another organism, H, was introduced into this habitat. The information regarding H is as follows:

- Organism H is a predator and not a prey.
- When the population of organism H increases, the populations of organisms E and F decrease.

(b) Based on the information given, add organism H into the food web above. [1]

(Go on to the next page)

Score	/
	4

33. Ali sets up an experiment in a dark room to find out if a plant needs light to make food.

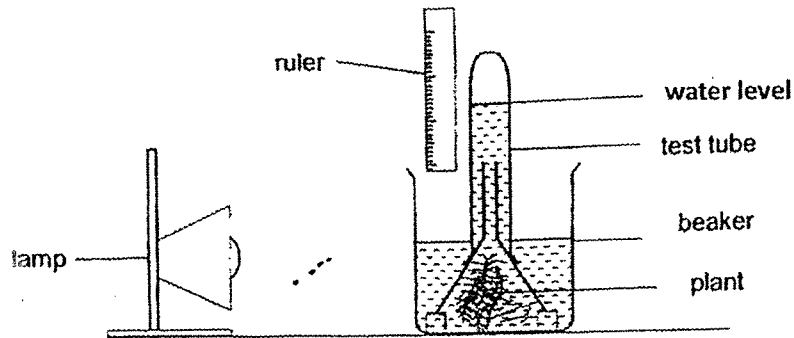

(a) What will happen to the water level if the plant is making food in the above set-up? [1]

(b) How should Ali carry out his experiment to confirm that the plant needs light to make food? [2]

(c) Ali adds into the beaker a substance that increases the amount of a gas. This gas speeds up the rate at which the plant makes food. Name this gas. [1]



34. Four strips made of different materials, A, B, C, and D, were dipped into a dish containing red-coloured water as shown.

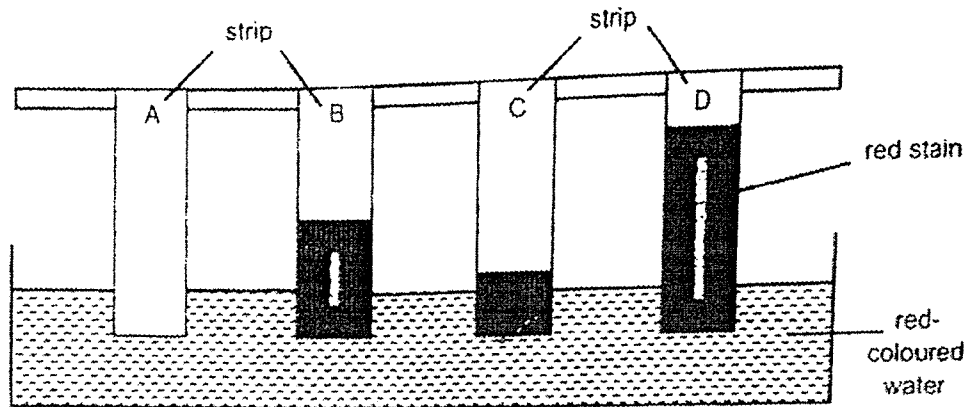

After ten minutes, all four strips were removed from the dish.
The length of red stain on each strip was measured and recorded below.

Material	Length of red stain on strip (cm)
A	0
B	10
C	4
D	21

- (a) Which property of the materials was being tested in the experiment? [1]

- (b) Explain which material A, B, C or D, you would use to make a raincoat. [1]

(Go on to the next page)

Score	/
	2

35. Chris receives an electrical toy train set. He notices that the buzzer on the front of the train only sounds when the whole train enters the tunnel. The tunnel is made of plastic, but the whole length of the ceiling of the tunnel is lined with a copper sheet.

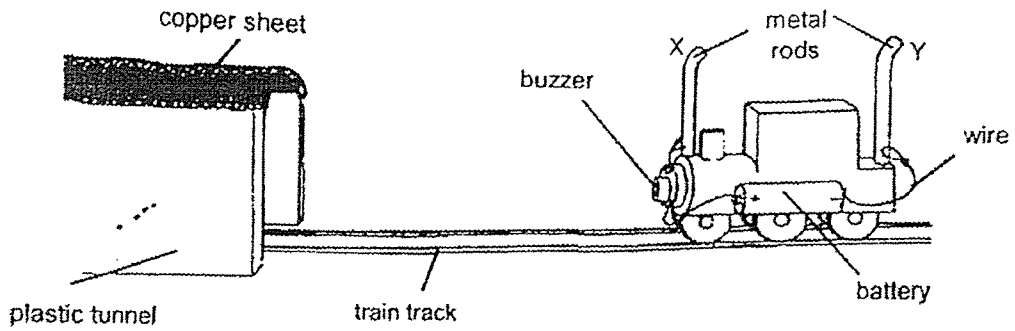

- (a) What is the property of copper that allows the buzzer to work in the plastic tunnel? [1]

- (b) Explain why the buzzer only sounds when the whole train is inside the tunnel. [2]

Chris would like to add one bulb as a headlight to his toy train so that when the whole train enters the tunnel, the bulb lights up.

- (c) Using circuit symbols, complete the circuit diagram below to show how the bulb was connected. [1]

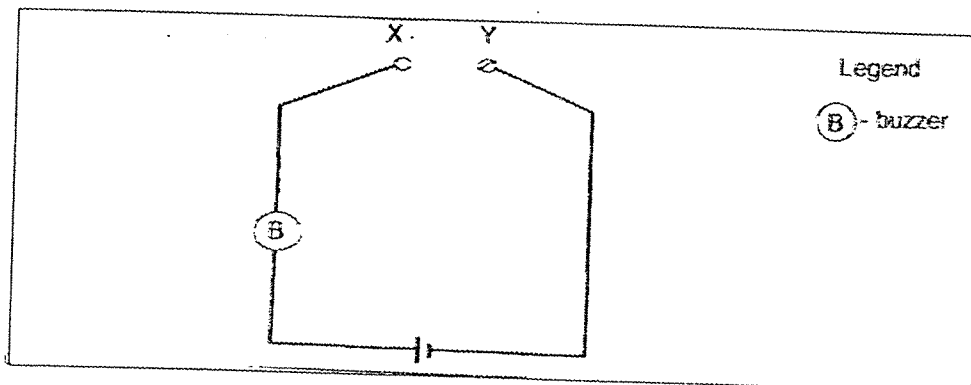

(Go on to the next page)

Score	/	4
-------	---	---

36. Monica hung three damp cloths of the same fabric, K, L and M. The cloths were each soaked with the same amount of water and were only partially wet.

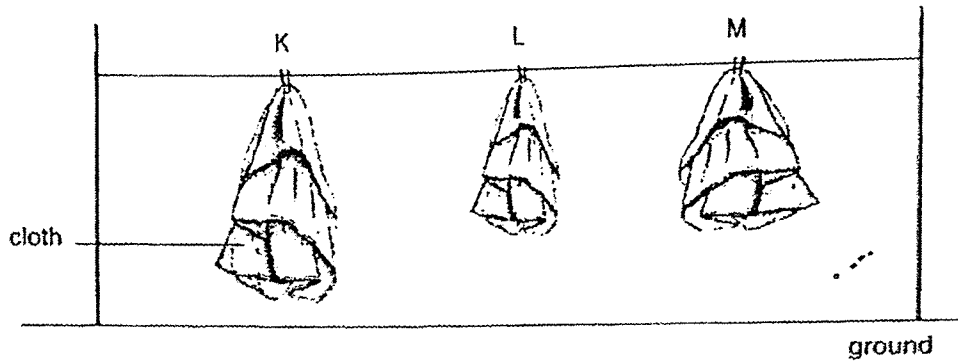

- (a) Explain how this method of hanging causes the cloths to dry more slowly. [1]

- (b) What can Monica do to make the cloths dry faster? Explain your answer. [2]

(Continued on the next page)

Before the cloths were completely dried, Monica took them down and ironed them. As she ironed the cloths, she noticed mist coming from the cloths.

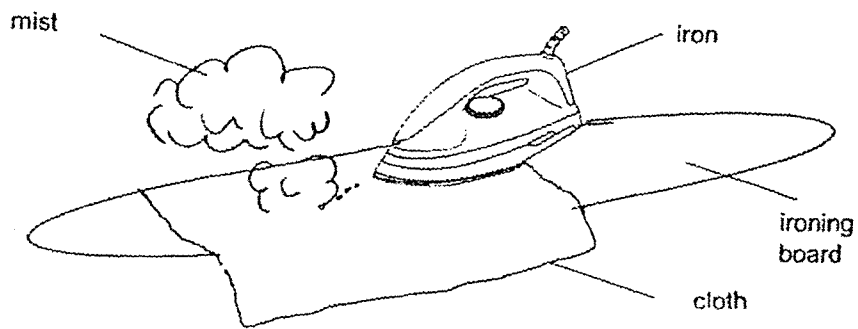

(c) Explain how the mist was formed.

[2]

(Go on to the next page)

Score	5
-------	---

37. Ben set up an apparatus to observe how a toy car moved along a plastic track from A to C. When the toy car was gently released at A, it moved down the plastic track.

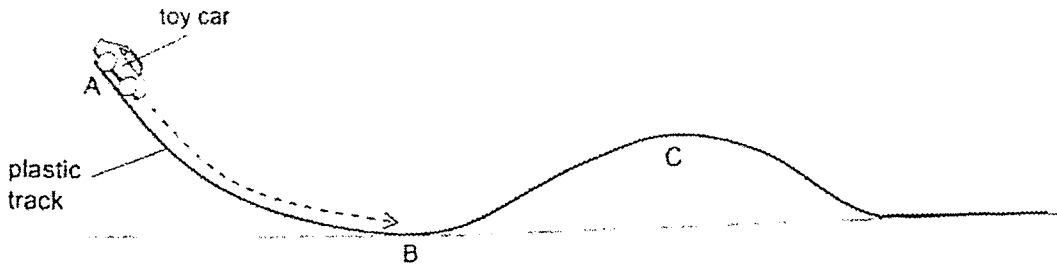

(a) What is the main energy conversion of the toy car as it travelled from A to B? [1]

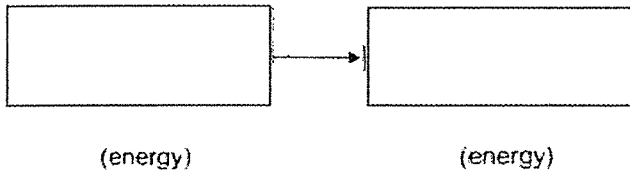

After the toy car travelled past B, Ben observed that the car moved up the slope, and into mid-air at X at a height that is lower than A but higher than C as shown below.

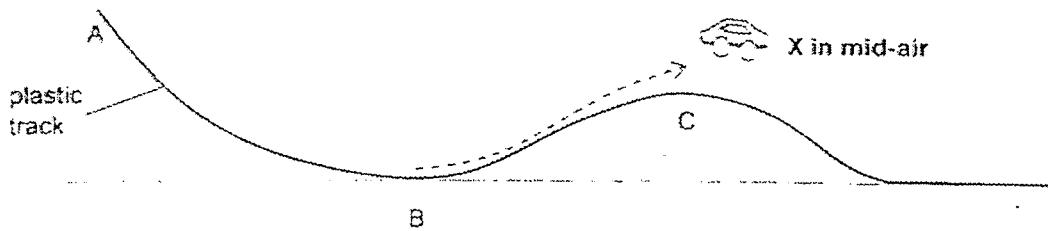

(b) Explain, in terms of energy conversion, the observations made of the toy car from B to X. [2]

(Continued on the next page)

- (C) Suggest where along the track. Ben should release the toy car to ensure it travels along the track only.
-

(Go on to the next page)

Score	3
-------	---

38. Rachel wanted to investigate how the number of fan blades on a windmill would affect the brightness of a bulb. She placed the windmill in front of a blower fan and observed that the bulb lit up as the fan blades turned.

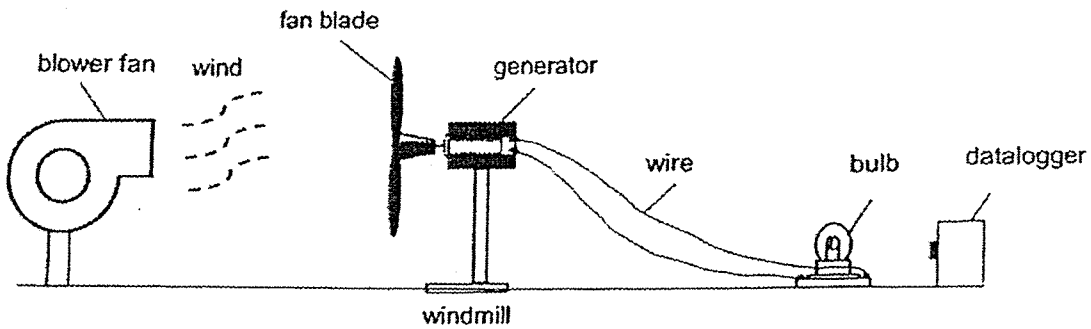

She recorded her results in the table below.

Number of fan blades	Brightness of the bulb (units)
2	25
3	34
5	49

- (a) Fill in the boxes to show the energy conversions of the experiment. [2]

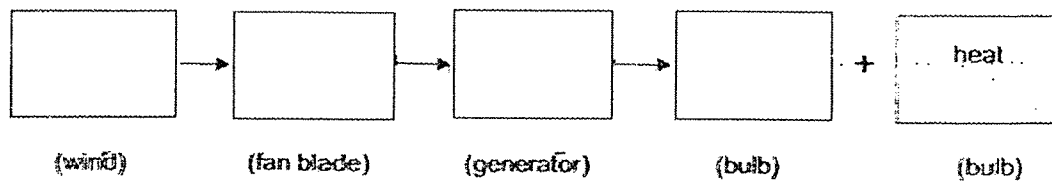

(Continued on the next page)

- 39 Ravin releases a toy car from the top of the ramp. When the toy car hits the cardboard box at the base of the ramp, the box moves a distance before coming to a stop.



- (a) Name the two forces acting on the toy car as it rolls down the ramp. [1]

- (b) Explain why the box came to a stop after it moved a distance. [1]

- (c) State one effect of forces when the toy car hits the cardboard box. [1]

- (d) Ravin repeats the same experiment with only one change. He uses a ramp with a smoother surface. State the hypothesis of this experiment. [1]

(Go on to the next page)

Score	4
-------	---

- (b) What would the brightness of the bulb most likely be if a windmill with four fan blades was tested? [1]

- (c) Besides the speed of the blower fan, how could Rachel ensure that the amount of wind was kept constant? [1]

(Go on to the next page)

Score	4
-------	---

- 40 Jerome wanted to investigate the effect of the length of a stretched elastic band on the distance travelled by object A. He prepared the set-up as shown. The original length of the elastic band is 10 cm.

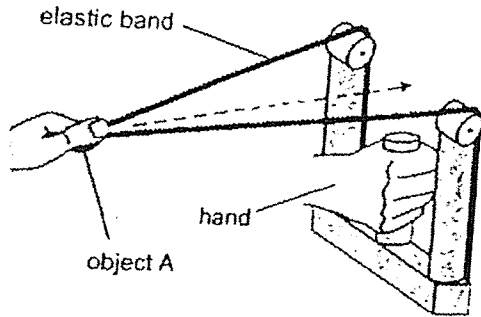

Jerome recorded his results in the table below.

Length of the stretched elastic band (cm)	Distance moved by object A			
	First try (cm)	Second try (cm)	Third try (cm)	Average (cm)
15	6.5	6.7	6.9	6.7
20	8.2	8.3	8.4	8.3
25	12.3	12.5	12.1	12.3

- (a) What is the relationship between the length of the stretched elastic band and the distance moved by object A? [1]
- _____
- _____
- (b) Explain, using forces, your answer in part (a). [1]
- _____
- _____
- (c) Why did Jerome perform the experiment three times for each length of the stretched elastic band? [1]
- _____

End of Paper

